

Language Academy of Sacramento/Academia de Idiomas de Sacramento
 A Two-Way Spanish Immersion Public Charter School/Una Escuela Pública de Inmersión Dual en Español
 2850 49th Street, Sacramento, CA 95817

Agenda/Agenda

BOARD MEETING/ REUNIÓN DE LA MESA

August 1, 2024 at 5:30pm/jueves, 1 de agosto del 2024 a las 5:30pm
 Room 8/Salón 8

Members of the public who wish to access this Board meeting may do so at:
[Zoom Link](#) You may also call in using the Zoom phone number: (669) 900-6833;
[Meeting ID: 912 0068 0381](#) [Passcode: 777292](#)

Members of the public who wish to comment during the Board meeting may use the “raise hand” tool on the Zoom platform. Members of the public calling in will be given the opportunity to address the Board during the meeting. Individual comments will be limited to three (3) minutes. If an interpreter is needed for comments, they will be translated to English and the time limit shall be six (6) minutes. The Board may limit the total time for public comment to a reasonable time. The Board reserves the right to mute or remove a participant from the meeting if the participant unreasonably disrupts the Board meeting (see additional information regarding (IIA) Oral Communications below.

I. PRELIMINARY/PRELIMINARIO

A. CALL TO ORDER/Convocatoria

Meeting was called to order by/La junta fue convocada por _____ at ____: ____ p.m.

B. ROLL CALL/Asistencia

	Name/Nombre	Role/Miembro	Present/ Presente	Absent/ Ausente
1.	Garduño-Medina, Elena	Parent/Madre (23-26) Vice President/Vicepresidenta		
2.	Jose Luis Rodríguez	Parent/Padre(22-25)		
3.	Alex Dickson	Parent/Madre (21-24)		
4.	Adriana Yáñez-Gutiérrez	Staff/Personal (23-26)		
5.	Alex Hayes	Teacher/Maestro (22-25) President/Presidenta		
6.	Rosa Lomelí	Teacher/Maestra (21-24) Secretary/Secretaria *Teleconference location: 2720 41 st Avenue, Soquel, CA 95073		
7.	Yesenia Ramírez-Huamani	Community Member/Miembro Comunitario (23-26) Treasurer/Tesorera		
8.	Luisana Victorica	Community Member/Miembro Comunitario (22-25) *Teleconference location: 2450 Alambra Boulevard, Sacramento, CA 95817		
9.	Nina Sylvains	Community Member/Miembro Comunitario (21-24) *Teleconference location: 2994 West Eight Mile Road, Stockton, CA 95209		
10.	Student Representative	Student Council President/Presidente del Concilio Estudiantil		
11.	Teejay Bersola	Director of Academic Accountability/Directora de Responsabilidad Académica		
12.	Judy Morales	Director of Business and Operations /Directora de negocios y operaciones		
13.	Eduardo de León	Executive Director/Director Ejecutivo		

C. APPROVAL OF AGENDA/Aprobación de la Agenda

It is recommended that the Board discuss and/or approve Agenda Item/Se recomienda que la Mesa Directiva discuta y/o apruebe.

Motion: _____ Second: _____ Vote: _____

D. MISSION/Misión

The LAS mission is to create a learning community where students: utilize bilingualism and biliteracy (Spanish and English) to achieve academic excellence and apply skills in real-world situations and diverse settings; develop and exhibit positive self-esteem, pride, confidence and respect for themselves and others; demonstrate leadership skills in order to build bridges between communities and apply critical thinking skills to solve problems, promote social justice, and create change in society.

La misión de LAS es crear una comunidad de aprendizaje donde los estudiantes: utilizan el bilingüismo y la alfabetización bilingüe (español e inglés) para alcanzar la excelencia académica y aplicar destrezas en situaciones del mundo real y en diversos entornos; desarrollan y exhiben una autoestima positiva, orgullo, confianza y respeto por sí mismos y otros; demuestran habilidades de liderazgo con el fin de establecer puentes entre comunidades y aplicar habilidades de pensamiento crítico para resolver problemas, fomentar la justicia social, y crear un cambio en la sociedad.

II. COMMUNICATIONS NORMS/NORMAS DE COMUNICACION

- A. ORAL COMMUNICATIONS/Comunicaciones Verbales:** Non-agenda items: no individual presentation shall be for more than three (3) minutes and the total time for this purpose shall not exceed fifteen (15) minutes. Board members will not respond to presentations and no action can be taken. However, the Board may give direction to staff following a presentation./*Temas no presentados en la agenda: Ningún individuo presentará por más de tres (3) minutos y el tiempo total para este segmento no pasará de quince (15) minutos. Los miembros de la Mesa Directiva no contestarán preguntas y ningún voto tomará acabo. Sin embargo, los Miembros de la Mesa Directiva pueden dar instrucciones al personal presentando los temas.*

- 1. Public Comments (maximum of three (3) minutes per speaker)/Comentarios Públicos (máximo de 3 minutos por persona)**

III. ITEMS SCHEDULED FOR DISCUSSION AND/OR ACTION – ARTICULOS PROGRAMADOS PARA DISCUSIÓN Y/O ACCIÓN

A. Facilities - Revision of school calendar, change of start date – School Leadership (60 min.)

- i. Public Comments (maximum of three (3) minutes per speaker)/Comentarios Públicos (máximo de 3 minutos por persona)**

It is recommended that the Board discuss and/or approve Agenda Item /*Se recomienda que la Mesa Directiva discuta y/o apruebe.*

Motion: _____ Second: _____ Vote: _____

IV. FUTURE MEETINGS/Próxima Junta

- A.) Next Meeting: Thursday, August 22, 2024 at 5:30pm – jueves, 22 de agosto de 2024 a las 5:30pm**

V. FUTURE AGENDA ITEMS/Temas para agendas futuras

VI. ADJOURNMENT/Clausura

The meeting was adjourned at ____: ____ p.m./*La junta terminó a las ____: ____ p.m.*

Motion: _____ Second: _____ Vote: _____

In compliance with the Americans with Disabilities Act (ADA) and upon request, the School may furnish reasonable auxiliary aids and services to qualified individuals with disabilities. Individuals who require appropriate alternative modifications of the agenda in order to participate in Board meetings are invited to contact the LAS office. En conformidad con la Acta de Americanos Incapacitados (ADA) y con el pedido formal, la escuela puede proveer servicios o la ayuda a individuos con incapacidades. Individuos que requieren servicios especiales para participar en la junta de la Mesa Directiva están invitados comunicarse con la directora para hacer arreglos.



Board Meeting Date: August 1, 2024

Subject: Facilities Committee and Modernization Update

- Information Item Only
- Approval on Consent Agenda
- Conference (for discussion only)
- Conference/First Reading (Action Anticipated: _____)
- Conference/Action
- Action

Facilities Update:

The modernization of the core building continues to move through August 2024. Unfortunately, there have been delays, primarily due to issues with classroom casework. These delays stem from initial bidding delay, a redesign by the Facilities Committee, manufacturing backlogs, and unforeseen site plumbing issues. The construction team, Intergra and RGA/HMC, have been working diligently to complete the work as well as procure the necessary casework from multiple vendors with maintaining the quality and integrity of the casework.

School administration and the construction team propose moving the first day of school from Tuesday, September 3, 2024, to Monday, September 9, 2024. This four (4) day adjustment will allow teachers to move into a workable space with 50% of the casework installed, ultimately creating an optimal learning environment for our all our students.

The remaining casework will be installed in phases through October and November. All other components of the project are on schedule to be completed within the agreed-upon timeframe (see attached schedule).

Pending Board decision, school office team will send the necessary information to our parent community via USPS, email, text, and social media posts, as well as be available to answer questions.

Financial Impact:

LAS does not anticipate an adverse financial impact, as the school will maintain the required 175 state-mandated instructional days and 194 staff contracted days.

Attachments:

1. Proposed Revision to the Calendar
2. Board Approved Calendar
3. Contractors Schedule

Estimated Time of Presentation: 60 min
Submitted By: Facilities Committee
Date: 08.01.2024

Revised 2024-2025 School Calendar				
Members	Aye	Nay	Abstain	Absent
Garduño-Medina, Elena				
Rodríguez, José Luis				
Dickson, Alex				
Yáñez-Gutiérrez, Adriana				
Hayes, Alex				
Lomelí, Rosa				
Ramírez,-Huamaní, Yesenia				
Victorica, Luisana				
Sylvains, Nina				
Totals:				

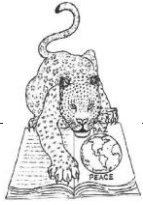

Fecha de la Reunión: 1 de agosto del 2024

Tema: Comité de plantel escolar

- Artículo de información
- Aprobación en la Agenda de Consentimiento
- Conferencia (solo para discutir)
- Conferencia/Primera lectura (Acción Anticipado: _____)
- Conferencia/Acción
- Acción

Actualización del Comité

Actualización de las instalaciones:

La modernización de los edificios centrales sigue avanzando en agosto de 2024. Lamentablemente, se han producido retrasos, debidos principalmente a problemas con el mobiliario de las aulas. Estos retrasos se deben al retraso inicial en la licitación, a un rediseño por parte del Comité del Plantel y a retrasos en la fabricación. El equipo de construcción, Intergra y RGA/HMC, han trabajado con diligencia para completar el trabajo necesario y para conseguir los mobiliarios necesarios de varios proveedores, simultáneamente manteniendo la calidad y la integridad.

La administración escolar y el equipo de construcción proponen trasladar el primer día de clase del martes 1 de septiembre de 2024 al lunes 9 de septiembre de 2024. Este ajuste de cuatro (4) días permitirá al personal trasladarse a un espacio viable con el 50% de la carpintería instalada, creando en salón de aprendizaje óptimo para todos nuestros alumnos.

El resto de los mobiliarios se instalará por fases a lo largo de octubre y noviembre. Todos los demás componentes del proyecto se completarán en el plazo acordado (véase el calendario adjunto).

En cuanto decida de la Mesa Directiva, el personal de la escuela enviará la información necesaria a nuestra comunidad de padres a través de USPS, correo electrónico, mensajes de texto y publicaciones en las redes sociales y estarán disponibles para contestar preguntas.

Impacto financiero:

LAS no anticipa un impacto financiero adverso, ya que la escuela mantendrá los 175 días académicos exigidos por el estado y los 194 días contratados por el personal.

Anexos:

1. Propuesta de revisión del calendario
2. Calendario aprobado por la Mesa Directiva
3. Calendario de contratistas



Core Modernization Project

School Calendar Revision

LANGUAGE ACADEMY OF SACRAMENTO
Governing Board Meeting
August 1, 2024

Delay #1 - Original Bid

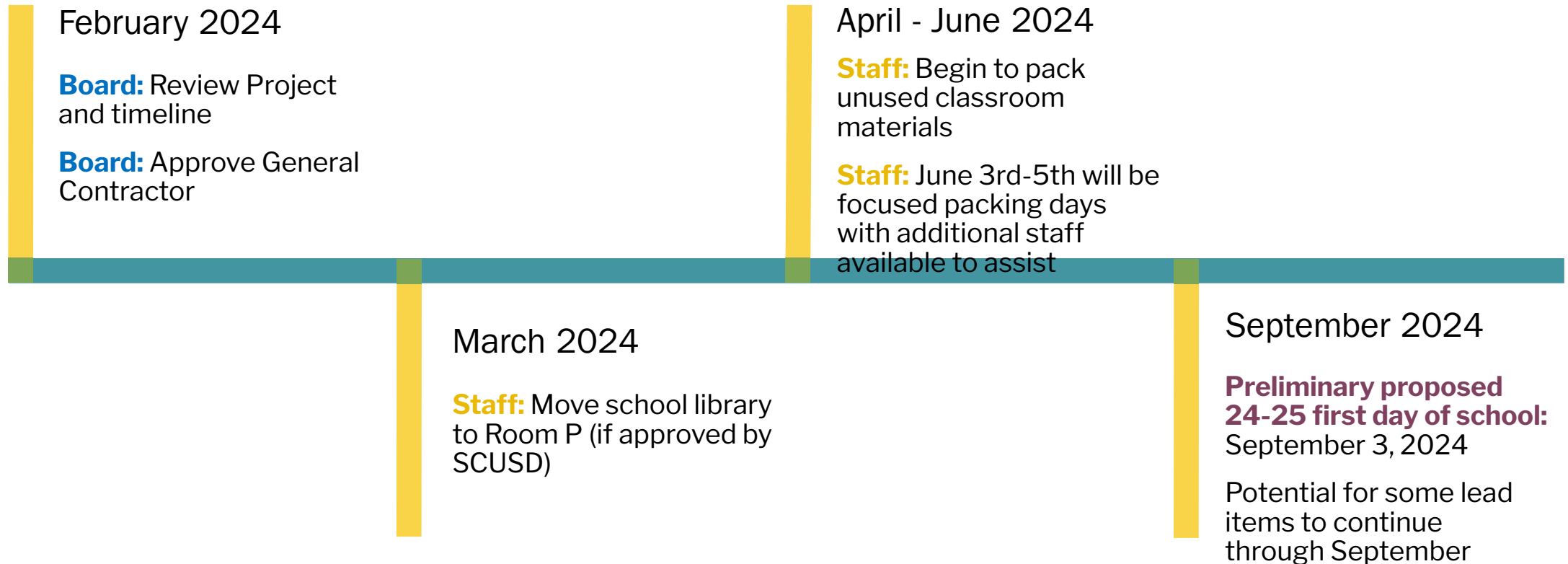

Rebid Construction Schedule

March 2024

- Advertise to bid, 3/26 & 4/2
- Pre-conference Mandatory Mtg, 4/3
- Bid Proposal Due, 4/15

May - August 2024

- Begin construction. 5/13
- Construction on site, classrooms 6/3
- Classroom occupancy, 8/19

April 2024

- Governing Board, 4/25
 - Award-winning bid
- Pre-Construction Activities, 4/29
 - Bond Preparation - Contractor
 - Contract Execution - LAS Legal
- Charter Safe Property and Liability Insurance
 - Establish Builder Risk Insurance Coverage - LAS Leadership

September 2024

- Students back on campus, 9/3
- Completion library and student restroom, 9/31

Delay #2 - Typical Classroom

- Tackable wall finish
- New cabinets and bookshelves
- New roller shades at windows
- ADA sinks and signage
- Updated power, data, technology

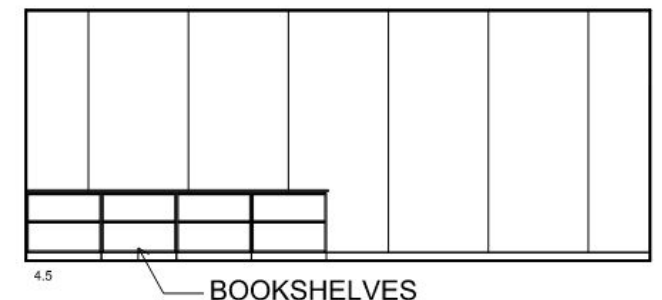
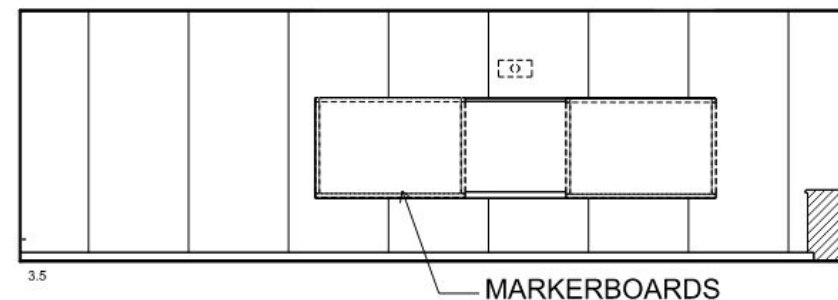
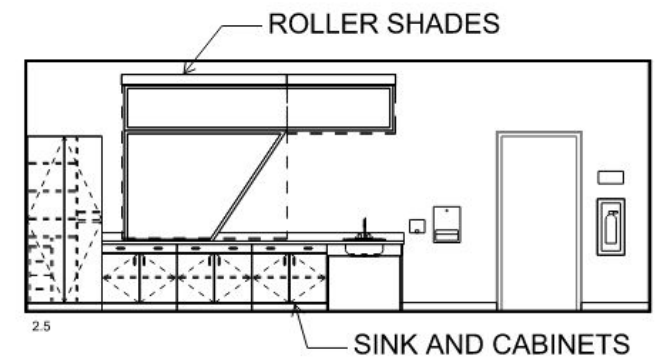
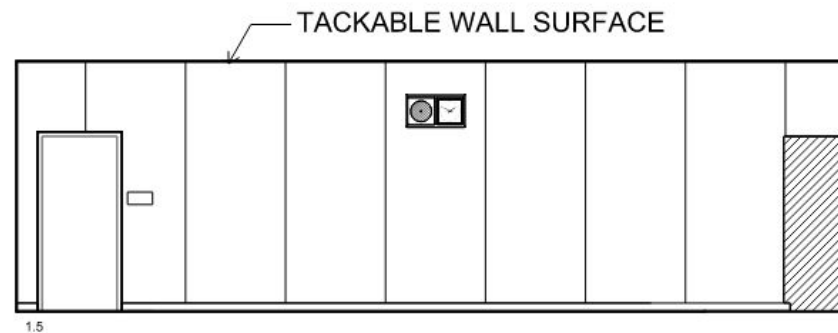

Delay #2 - Revised Classroom per Facilities Committee

- Additional cabinets and bookshelves
- Revised placement orientation of cabinets
- Changes required additional electrical and IT revision
- Updated well within the Board adopted construction budget
- Unforeseen Plumbing reconfiguration to accommodate redesign and ADA requirements
- Backlog of Manufacture availability

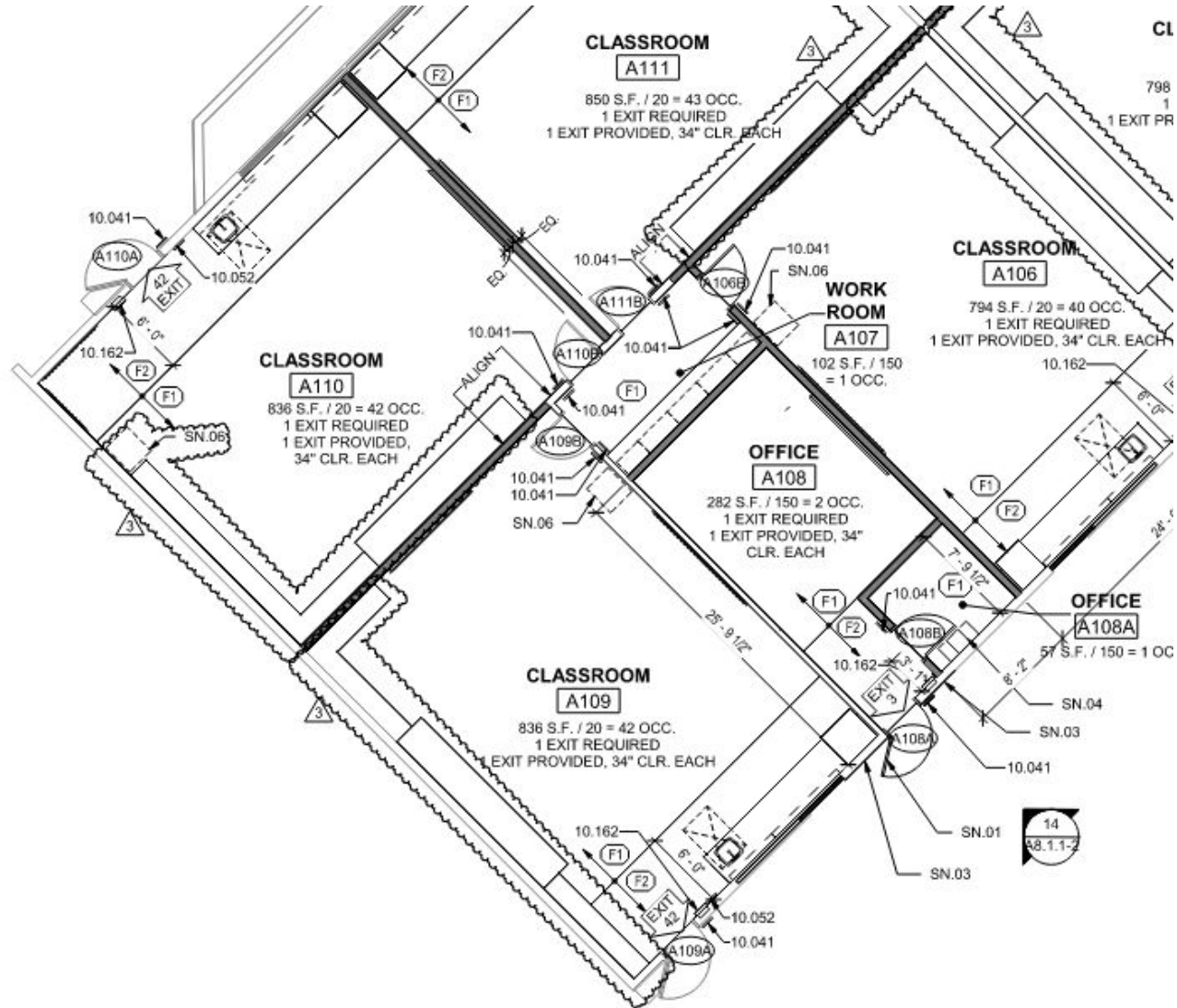

Delay #2 - Revised Classroom per Facilities Committee

- Additional cabinets and bookshelves
- Revised placement orientation of cabinets
- Changes required additional electrical and IT revision
- Updated well within the Board adopted construction budget
- Unforeseen Plumbing reconfiguration to accommodate redesign and ADA requirements
- Backlog of Manufacture availability

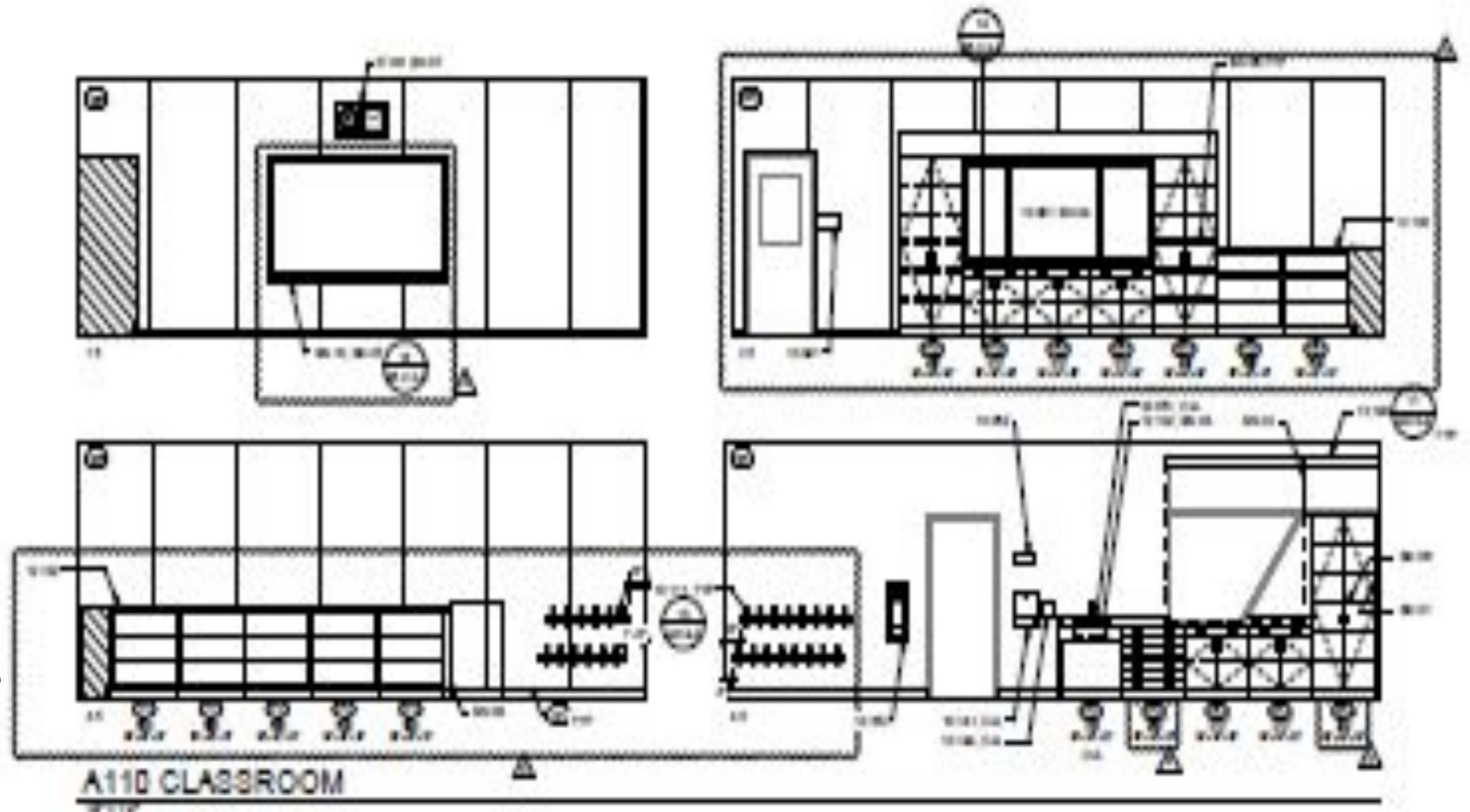

Delay #3

- Concrete sidewalk replacement
- Entrance gate replacement
- ADA upgrades at exterior stage

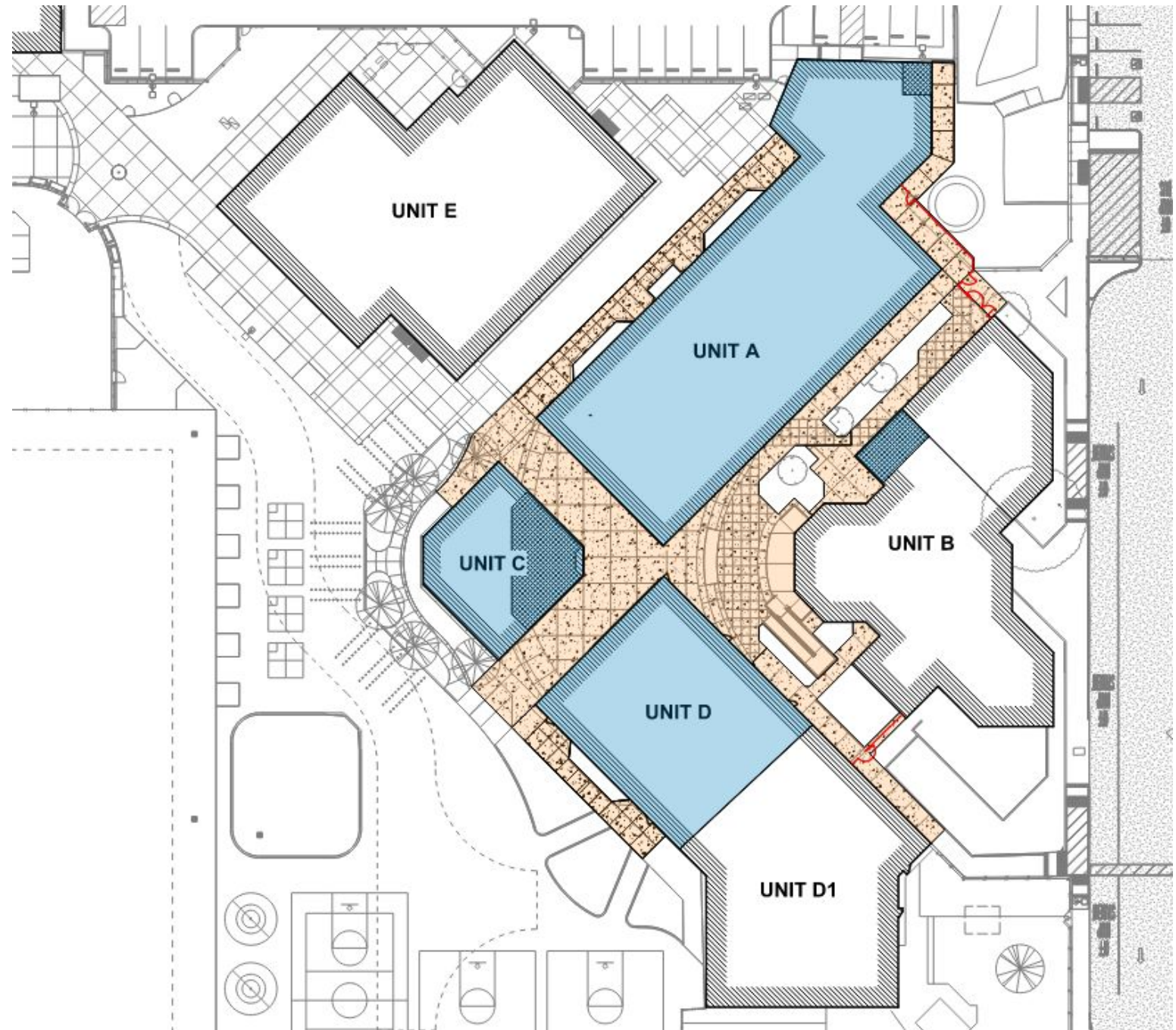

Delay #3 - Site Plumbing below path of travel

- Extremely shallow site plumbing that includes frail piping that was unforeseen

2" drains from sinks



4" Storm Drain



4" Sewer

Proposed School Calendar Revision

- Move the first day of school by four (4) days
- This adjustment will allow for:
 - teachers to move into a workable space with 50% of the casework installed, ultimately creating an optimal learning environment for students.
 - families to return to campus with minimal impact to parking or accessibility to campus
 - minimal construction personnel or equipment on campus

Primary Changes to the 2024-2025 School calendar

- Delay the start of school by four (4) days from Tuesday, September 3rd to Monday, September 9th

GB Adopted 02.23.2024

September 2024						
Sun	Mon	Tue	Wed	Thu	Fri	Sat
1	H	3	4	5	6	7
8	9	10	11	12	13	14
15	16	17	18	19	20	21
22	23	24	25	26	27	28
29	30					

20 work days
 19 instructional days
 9/25: TK-8 Assessment Day

Proposed Change 08.01.2024

September 2024						
Sun	Mon	Tue	Wed	Thu	Fri	Sat
1	H	3	4	5	6	7
8	9	10	11	12	13	14
15	16	17	18	19	20	21
22	23	24	25	26	27	28
29	30					

20 work days
 16 instructional days

Primary Changes to the 2024-2025 School calendar

- Eliminate one assessment day (in current year only) and replacing it with an additional instructional day

GB Approved 02.23.2024

September 2024							
Sun	Mon	Tue	Wed	Thu	Fri	Sat	
w1	1	H	3	4	5	6	7
w2	8	9	10	11	12	13	14
w3	15	16	17	18	19	20	21
w4	22	23	24	25	26	27	28
w5	29	30					

20 work days
19 instructional days
9/25: TK-8 Assessment Day

October 2024							
Sun	Mon	Tue	Wed	Thu	Fri	Sat	
w5			1	2	3	4	5
w6	6	7	8	9	10	11	12
w7	13	14	15	16	17	18	19
w8	20	21	22	23	24	25	26
w9	27	28	29	30	31		

23 work days
22 instructional days
10/23: TK-8 Assessment Day

Proposed Change 08.01.2024

September 2024							
Sun	Mon	Tue	Wed	Thu	Fri	Sat	
w1	1	H	3	4	5	6	7
w2	8	9	10	11	12	13	14
w3	15	16	17	18	19	20	21
w4	22	23	24	25	26	27	28
w5	29	30					

20 work days
16 instructional days

October 2024							
Sun	Mon	Tue	Wed	Thu	Fri	Sat	
w5			1	2	3	4	5
w6	6	7	8	9	10	11	12
w7	13	14	15	16	17	18	19
w8	20	21	22	23	24	25	26
w9	27	28	29	30	31		

23 work days
22 instructional days
10/2: TK-8 Assessment Day

Primary Changes to the 2024-2025 School calendar

- Extend the end of the school year by three (3) days

GB Approved 02.23.2024

June 2025						
Sun	Mon	Tue	Wed	Thu	Fri	Sat
1	2	3	4	5	6	7
8	9	10	11	12	13	14
15	16	17	18	H	20	21
22	23	24	25	26	27	28
29	30					

14 work days
9 instructional days

Proposed Change 08.01.2024

June 2025						
Sun	Mon	Tue	Wed	Thu	Fri	Sat
1	2	3	4	5	6	7
8	9	10	11	12	13	14
15	16	17	18	H	20	21
22	23	24	25	26	27	28
29	30					

14 work days
9 instructional days
19 Juneteenth

Primary Changes to the 2024-2025 School calendar

- Contracted Teacher work days are PENDING - School Leadership will continue to explore the best options for all teachers and decide on a start and end date for staff while maintaining the 194 contracted days.

GB Approved 02.23.2024

August 2024						
Sun	Mon	Tue	Wed	Thu	Fri	Sat
				1	2	3
4	5	6	7	8	9	10
11	12	13	14	15	16	17
18	19	20	21	22	23	24
25	26	27	28	29	30	31

10 work days
0 instructional days

September 2024						
Sun	Mon	Tue	Wed	Thu	Fri	Sat
1	H	3	4	5	6	7
8	9	10	11	12	13	14
15	16	17	18	19	20	21
22	23	24	25	26	27	28
29	30					

20 work days
19 instructional days
9/25: TK-8 Assessment Day

Proposed Change 08.01.2024

August 2024						
Sun	Mon	Tue	Wed	Thu	Fri	Sat
				1	2	3
4	5	6	7	8	9	10
11	12	13	14	15	16	17
18	19	20	21	22	23	24
25	26	27	28	29	30	31

8 work days
0 instructional days

September 2024						
Sun	Mon	Tue	Wed	Thu	Fri	Sat
1	H	3	4	5	6	7
8	9	10	11	12	13	14
15	16	17	18	19	20	21
22	23	24	25	26	27	28
29	30					

20 work days
16 instructional days

June 2025						
Sun	Mon	Tue	Wed	Thu	Fri	Sat
1	2	3	4	5	6	7
8	9	10	11	12	13	14
15	16	17	18	H	20	21
22	23	24	25	26	27	28
29	30					

14 work days
9 instructional days

June 2025						
Sun	Mon	Tue	Wed	Thu	Fri	Sat
1	2	3	4	5	6	7
8	9	10	11	12	13	14
15	16	17	18	H	20	21
22	23	24	25	26	27	28
29	30					

14 work days
12 instructional days
19 Juneteenth

Dissemination of Information



Pending Board decision, the school office team will send the necessary information to our parent community via:

- USPS
- Email
- Remind (text)
- Social media posts

Staff will be readily available to answer any questions that our school community may have.

Recommendation



School Leadership requests that the Board approve the revised 2024-2025 School Calendar.



Core Modernization Increments 1 & 2
Language Academy of Sacramento
July 30th, 2024

Schedule Summary for Start of School

Increment 1 & 2 Sitework & Exterior Improvements Completion 09/02/2024

- Site Underground Utilities and Plumbing Completed 08/10/24
- Earthwork and Grading Completed 08/12/24
- Concrete Forming & Layout Completed 08/16/24
- Concrete Pour & Finish Completion 08/27/24 (Starting 08/16)
- Metal Fencing, Gates & Railing (09/02/2024)

Increment 2 Buildings A & D Interior Improvements Completion 09/02/2024

- CCD 2 Electrical Drawing Updates Received 07/24/24 , Completion 08/03
- Drywall Complete 08/12 (Walls Closed)
- Suspended Ceilings Complete 08/23
- Lighting Completion 08/30
- Casework & Countertops Completion 08/31/2024 (CCD 2 Millwork To Be Completed 11/29)
- Tackboard Panel Installation Completion 08/26/2024
- Flooring Completion 08/31
- MEP Fixture and Finish Trim out 09/02/2024

Interior / Exterior Cleaning

- 08/28-09/03/24 prior to Start of School

Increment 1 Buildings B & C Restrooms & Library

- Building C Library / Restrooms Completion 10/14/2024

TK Classrooms in Building A , 114 & 117

- CCD Revision in progress, TBD Completion Date

Note: Please note; TK Classrooms in Building A , 114 & 117 are excluded, awaiting changes in future CCD, Increment 1 Buildings B & C are excluded, and Millwork per CCD 2 are excluded in the 09/02/24 completion. All Millwork to be complete 11/29/2024.

Please feel free to reach out to Isaac Arias at 925-758-9078 should you have any questions. Thank you.

**Language Academy of Sacramento
2024-2025
Academic Calendar_Board Approved_02232024**

Length of 2024 Summer Break:	9 weeks
Certificated Start Date:	August 19, 2024
First Day of School:	September 3, 2024

Length of Winter Break:	2 weeks
Last Day of School:	June 12, 2025
Certificated End Date:	June 19, 2025

July 2024						
Sun	Mon	Tue	Wed	Thu	Fri	Sat
	1	2	3	4	5	6
7	8	9	10	11	12	13
14	15	16	17	18	19	20
21	22	23	24	25	26	27
28	29	30	31			

0 work days
0 instructional days

August 2024						
Sun	Mon	Tue	Wed	Thu	Fri	Sat
				1	2	3
4	5	6	7	8	9	10
11	12	13	14	15	16	17
18	19	20	21	22	23	24
25	26	27	28	29	30	31

8 work days
0 instructional days

September 2024						
Sun	Mon	Tue	Wed	Thu	Fri	Sat
1	H	3	4	5	6	7
8	9	10	11	12	13	14
15	16	17	18	19	20	21
22	23	24	25	26	27	28
29	30					

20 work days
19 instructional days
9/25: TK-8 Assessment Day

October 2024						
Sun	Mon	Tue	Wed	Thu	Fri	Sat
		1	2	3	4	5
6	7	8	9	10	11	12
13	14	15	16	17	18	19
20	21	22	23	24	25	26
27	28	29	30	31		

23 work days
22 instructional days
10/23: TK-8 Assessment Day

November 2024						
Sun	Mon	Tue	Wed	Thu	Fri	Sat
					1	2
3	4	5	6	7	8	9
10	H	12	13	14	15	16
17	18	19	20	21	22	23
24	25	26	27	28	29	30

15 work days
15 instructional days
*PT Conference Week

December 2024						
Sun	Mon	Tue	Wed	Thu	Fri	Sat
1	2	3	4	5	6	7
8	9	10	11	12	13	14
15	16	17	18	19	20	21
22	H	H	H	H	H	28
29	H	H				

15 work days
15 instructional days

January 2025						
Sun	Mon	Tue	Wed	Thu	Fri	Sat
			H	H	H	4
5	6	7	8	9	10	11
12	13	14	15	16	17	18
19	H	21	22	23	24	25
26	27	28	29	30	31	

19 work days
19 instructional days (TK-5)
18 instructional days (MS)
1/8: MS Assessment Day

February 2025						
Sun	Mon	Tue	Wed	Thu	Fri	Sat
						1
2	3	4	5	6	7	8
9	10	11	12	13	14	15
16	H	18	19	20	21	22
23	24	25	26	27	28	

19 work days
19 instructional days (MS)
18 instructional days (TK-5)
2/12: TK-5 Assessment Day
2/24: 100th Day of School

March 2025						
Sun	Mon	Tue	Wed	Thu	Fri	Sat
						1
2	3	4	5	6	7	8
9	10	11	12	13	14	15
16	17	18	19	20	21	22
23	24	25	26	27	28	29
30	31					

21 work days
21 instructional days
3/31: César Chávez Day of Service
*PT Conference Week

April 2025						
Sun	Mon	Tue	Wed	Thu	Fri	Sat
		1	2	3	4	5
6	7	8	9	10	11	12
13	H	H	H	H	H	19
20	21	22	23	24	25	26
27	28	29	30			

17 work days
17 instructional days

May 2025						
Sun	Mon	Tue	Wed	Thu	Fri	Sat
				1	2	3
4	5	6	7	8	9	10
11	12	13	14	15	16	17
18	19	20	21	22	23	24
25	H	27	28	29	30	31

21 work days
20 instructional days
5/8: TK-8 Assessment Day

June 2025						
Sun	Mon	Tue	Wed	Thu	Fri	Sat
1	2	3	4	5	6	7
8	9	10	11	12	13	14
15	16	17	18	H	20	21
22	23	24	25	26	27	28
29	30					

14 work days
9 instructional days

	Work Days
	Full Day/Work Day
	Minimum Day/Work Day
	Holiday/Non-Work Day
	Office Open

TK-5													
Month	J	A	S	O	N	D	J	F	M	A	M	J	Total
Work Days	0	10	20	23	15	15	19	19	21	17	21	14	194
Instructional Days	0	0	19	22	15	15	19	18	21	17	20	9	175

Middle School													
Month	J	A	S	O	N	D	J	F	M	A	M	J	Total
Work Days	0	10	20	23	15	15	19	19	21	17	21	14	194
Instructional Days	0	0	19	22	15	15	18	19	21	17	20	9	175

	TK-5	MS
Assessment Date	9/25/2024	9/25/2024
Grades Due Date		
Assessment Date	10/23/2024	10/23/2024
Grades Due Date	10/21/2024	10/21/2024
Assessment Date	2/12/2025	1/8/2025
Grades Due Date	2/3/2025	2/3/2025
Assessment Date	5/7/2025	5/7/2025
Grades Due Date	5/5/2025	5/5/2025

Language Academy of Sacramento 2024-2025 Academic Calendar_Proposed Revision_08012024

Length of 2024 Summer Break:	14 weeks
Certificated Start Date:	August 21, 2024
First Day of School:	September 9, 2024

Length of Winter Break:	2 weeks
Last Day of School:	June 17, 2025
Certificated End Date:	June 20, 2025

July 2024						
Sun	Mon	Tue	Wed	Thu	Fri	Sat
	1	2	3	4	5	6
7	8	9	10	11	12	13
14	15	16	17	18	19	20
21	22	23	24	25	26	27
28	29	30	31			

0 work days
0 instructional days

August 2024						
Sun	Mon	Tue	Wed	Thu	Fri	Sat
				1	2	3
4	5	6	7	8	9	10
11	12	13	14	15	16	17
18	19	20	21	22	23	24
25	26	27	28	29	30	31

8 work days
0 instructional days

September 2024						
Sun	Mon	Tue	Wed	Thu	Fri	Sat
1	H	3	4	5	6	7
8	9	10	11	12	13	14
15	16	17	18	19	20	21
22	23	24	25	26	27	28
29	30					

20 work days
16 instructional days

October 2024						
Sun	Mon	Tue	Wed	Thu	Fri	Sat
		1	2	3	4	5
6	7	8	9	10	11	12
13	14	15	16	17	18	19
20	21	22	23	24	25	26
27	28	29	30	31		

23 work days
22 instructional days
10/2: TK-8 Assessment Day

November 2024						
Sun	Mon	Tue	Wed	Thu	Fri	Sat
					1	2
3	4	5	6	7	8	9
10	H	12	13	14	15	16
17	18	19	20	21	22	23
24	25	26	27	28	29	30

w9
w10
w11
w12
15 work days
15 instructional days
*PT Conference Week

December 2024						
Sun	Mon	Tue	Wed	Thu	Fri	Sat
1	2	3	4	5	6	7
8	9	10	11	12	13	14
15	16	17	18	19	20	21
22	H	H	H	H	H	28
29	H	H				

15 work days
15 instructional days

January 2025						
Sun	Mon	Tue	Wed	Thu	Fri	Sat
			H	H	H	4
5	6	7	8	9	10	11
12	13	14	15	16	17	18
19	H	21	22	23	24	25
26	27	28	29	30	31	

19 work days
19 instructional days (TK-5)
18 instructional days (MS)
1/8: MS Assessment Day

February 2025						
Sun	Mon	Tue	Wed	Thu	Fri	Sat
						1
2	3	4	5	6	7	8
9	10	11	12	13	14	15
16	H	18	19	20	21	22
23	24	25	26	27	28	

19 work days
19 instructional days (MS)
18 instructional days (TK-5)
2/12: TK-5 Assessment Day
2/24: 100th Day of School

March 2025						
Sun	Mon	Tue	Wed	Thu	Fri	Sat
						1
2	3	4	5	6	7	8
9	10	11	12	13	14	15
16	17	18	19	20	21	22
23	24	25	26	27	28	29
30	31					

w24
w25
w26
w27
w28
21 work days
21 instructional days
3/31: César Chávez Day of Service
*PT Conference Week

April 2025						
Sun	Mon	Tue	Wed	Thu	Fri	Sat
		1	2	3	4	5
6	7	8	9	10	11	12
13	H	H	H	H	H	19
20	21	22	23	24	25	26
27	28	29	30			

17 work days
17 instructional days

May 2025						
Sun	Mon	Tue	Wed	Thu	Fri	Sat
				1	2	3
4	5	6	7	8	9	10
11	12	13	14	15	16	17
18	19	20	21	22	23	24
25	H	27	28	29	30	31

21 work days
20 instructional days
5/8: TK-8 Assessment Day

June 2025						
Sun	Mon	Tue	Wed	Thu	Fri	Sat
1	2	3	4	5	6	7
8	9	10	11	12	13	14
15	16	17	18	H	20	21
22	23	24	25	26	27	28
29	30					

14 work days
12 instructional days
19 Juneteenth

	Work Days
	Full Day/Work Day
	Minimum Day/Work Day
	Holiday/Non-Work Day
	Office Open

TK-5													
Month	J	A	S	O	N	D	J	F	M	A	M	J	Total
Work Days	0	8	20	23	15	15	19	19	21	17	21	16	194
Instructional Days	0	0	16	22	15	15	19	18	21	17	20	12	175

Middle School													
Month	J	A	S	O	N	D	J	F	M	A	M	J	Total
Work Days	0	8	20	23	15	15	19	19	21	17	21	16	194
Instructional Days	0	0	16	22	15	15	18	19	21	17	20	12	175

	TK-5	MS
Assessment Date	9/25/2024	9/25/2024
Grades Due Date		
Assessment Date	10/23/2024	10/23/2024
Grades Due Date	10/21/2024	10/21/2024
Assessment Date	2/12/2025	1/8/2025
Grades Due Date	2/3/2025	2/3/2025
Assessment Date	5/7/2025	5/7/2025
Grades Due Date	5/5/2025	5/5/2025